

NP-11-2-180-INT

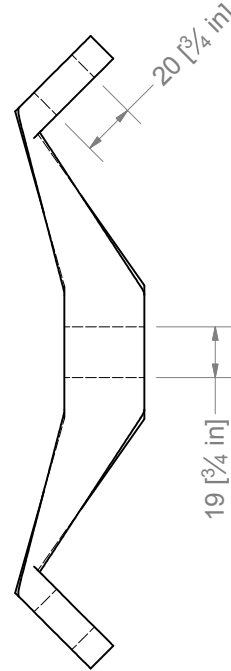
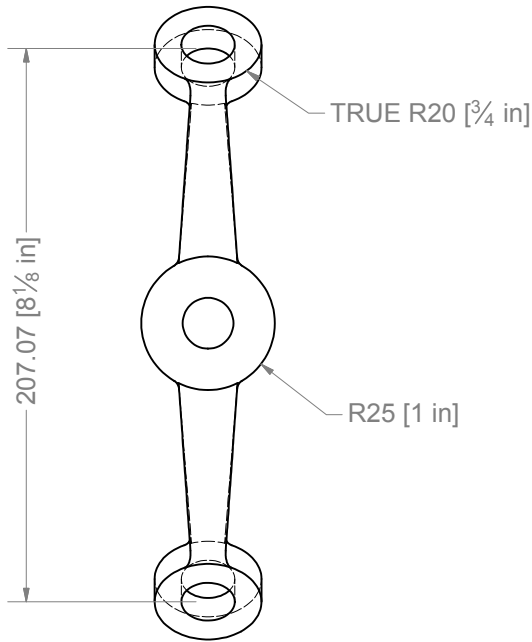
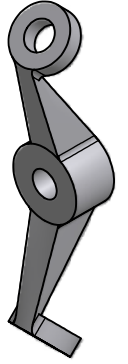
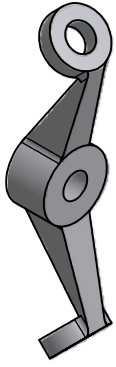

Details	
Item	Description
Catalogue#	NP-11-2-180-INT
Description	2 way, 180 degree internal. Centre point fixed conector
Material	CF8M cast grade, Equivalent wrought grade 316
Finish	Mechanical Satin Linish(#4) is standard, please note mechanical Mirror polished, Garnet sand, stainless steel shot blast and electro polishing are available by request

These drawings are for information and can not be deemed as engineered for use in project with out engineering certification

General Tolerances Unless Noted Otherwise			NUPRESS GROUP AUSTRALIA			
DIMENSION (mm)	TOL. for FAB.	TOL. for MACH.	NAME	DATE	This drawing is the property of the Nupress Group and is supplied on the understanding that it is not to be used or copied or communicated to any person without the written permission of the proprietors.	
			Drawn By:	CMC		20/03/2007
UP TO 6	±0.5	±0.1	Checked By:			
6 TO 30	±1.0	±0.2	Approved By:			
31 TO 120	±1.5	±0.3	A3 www.nupress.com.au			
121 TO 315	±2.0	±0.5	SCALE: DNS			
316 TO 1000	±2.5	±0.8	TITLE: NP-11-4-90-INT			
1001 TO 2000	±3.0	±1.0	Part No: NP11-2-180INT			
OVER 2000	±3.5	±1.2	Drawing Number: NP-11-4-90-INT		REV:	
DO NOT SCALE IF IN DOUBT, ASK!			All Dimensions are in mm [in]			Sheet 1 of 1