

NP-10-2-90

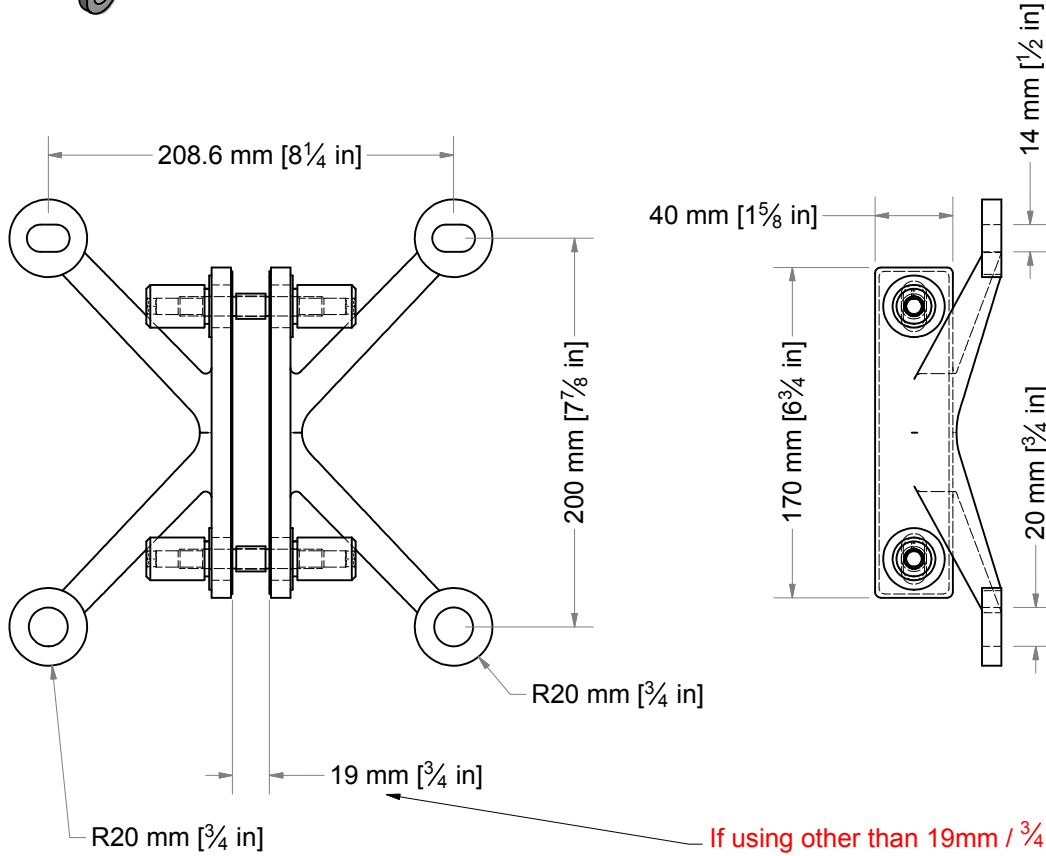
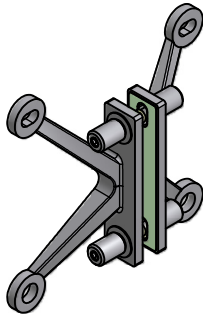

If using other than 19mm / 3/4" glass please specify

Details	
Item	Description
Catalogue#	NP-10-2-90
Description	4 way 90 degree . splcing point fixed conector (specify fin thickness at placement of order)
Material	CF8M cast grade, Equivalent wrought grade 316
Finish	Mechanical Satin Linish(#4) is standard, please note mechanical Mirror polished,Garnet sand, stainless steel shot blast and electro polishing are available by request

These drawings are for information and can not be deemed as engineered for use in project with out engineering certification

General Tolerances Unless Noted Otherwise			NUPRESS GROUP AUSTRALIA		
DIMENSION (mm)	TOL. for FAB.	TOL. for MACH.	Drawn By:	NAME	DATE
UP TO 6	±0.5	±0.1	CMC	CMC	15/03/2007
6 TO 30	±1.0	±0.2	Checked By:	cm	17/02/2009
31 TO 120	±1.5	±0.3	Approved By:	cmc	20/02/2009
121 TO 315	±2.0	±0.5	A3 www.nupress.com.au		
316 TO 1000	±2.5	±0.8	SCALE: DNS		
1001 TO 2000	±3.0	±1.0	TITLE: NP-10-2-90		
OVER 2000	±3.5	±1.2	Part No: NP10-2-19		
DO NOT SCALE IF IN DOUBT, ASK!			Drawing Number: NP-10-2-90		REV: 0
			All Dimensions are in mm [in]		
			Sheet 1 of 1		



This drawing is the property of the Nupress Group and is supplied on the understanding that it is not to be used or copied or communicated to any person without the written permission of the proprietors.